On the Electric Effect of Rotating a Dielectric in a Magnetic Field

Harold A. Wilson

Phil. Trans. R. Soc. Lond. A 1905 **204**, 121-137

doi: 10.1098/rsta.1905.0003

Email alerting service

Receive free email alerts when new articles cite this article - sign up in the box at the top right-hand corner of the article or click [here](#)

To subscribe to *Phil. Trans. R. Soc. Lond. A* go to: <http://rsta.royalsocietypublishing.org/subscriptions>

III. *On the Electric Effect of Rotating a Dielectric in a Magnetic Field.*

By HAROLD A. WILSON, *M.A., D.Sc., Fellow of Trinity College, Cambridge.*

Communicated by Professor J. J. THOMSON, F.R.S.

Received May 18,—Read June 2, 1904.

IT was shown by FARADAY in 1831 that an electromotive force is induced in a conductor moving in a magnetic field so as to cut the lines of magnetic force. The object of the experiments described in the present paper was to see if a similar effect exists in a dielectric when it moves in a magnetic field, and to measure the amount of the effect if it were found to exist.

According to MAXWELL'S electrodynamic theory, as developed by H. A. LORENTZ and by LARMOR, such an electromotive force should be produced in a dielectric, and should be equal to the electromotive force in a conductor multiplied by the factor $1 - K^{-1}$, where K is the specific inductive capacity of the dielectric.

It appears, from the experiments described below, that the effect in question does exist, and is very nearly of the amount predicted by the theory. The experiments, therefore, may be regarded as a confirmation of the theory in question.

The paper is divided into the following parts :—

- (1) Theory of the experiment; (2) description of apparatus; (3) method of experimenting and results obtained; (4) comparison of the results with theory; (5) summary of results and conclusion.

(1.) *Theory of the Experiment.*

IN FARADAY'S original experiment a metal disk was placed in a magnetic field perpendicular to the plane of the disk, and the axle of the disk and its circumference were connected by sliding contacts to a galvanometer. When the disk was rotated, a current passed through the galvanometer, showing that an electromotive force was induced in the disk by its motion in the magnetic field.

The method I have used is very analogous to that employed by FARADAY. A hollow cylinder of dielectric is rotated about its axis in a magnetic field parallel to the axis of the cylinder, and the inside and outside surfaces of the cylinder are

connected through sliding contacts to a quadrant electrometer. On reversing the direction of the magnetic field, a deflection of the electrometer needle is obtained, showing that an electric displacement has been produced in the cylinder.

The inside and outside surfaces of the cylinder are provided with thin metal coatings, and a sliding contact on the outside coating is connected to one pair of quadrants of the electrometer, while the inside coating is connected to the other pair of quadrants and to earth. Let r_2 be the radius of the outside surface of the cylinder, and r_1 that of the inside surface. Let the number of revolutions per second be n , and the magnetic force parallel to the axis of the cylinder be H . Then, if the cylinder were a conductor, the difference of potential V between the two surfaces would be given by the equation

$$V = n\pi (r_2^2 - r_1^2) H,$$

since V would be equal to the electromotive force induced in the cylinder. When the cylinder is composed of a dielectric of specific inductive capacity K , then, according to the electrodynamic theory of LORENTZ and LARMOR, the electromotive force E induced in the cylinder will be given by the equation

$$E = n\pi (r_2^2 - r_1^2) H (1 - K^{-1}).$$

Suppose that the two coatings of the cylinder are initially at zero potential, and that it is then set rotating in a magnetic field parallel to its axis. Let V be the resulting potential of the outside coating, the inside being permanently connected to earth. The electromotive force E will produce a charge on the inner surface of the outside coating, and an equal and opposite free charge on the outside surface of the coating, which will distribute itself over the connecting wire and insulated pair of quadrants of the electrometer.

We have now to consider the electrostatic induction across the dielectric mass moving through the ether, say, with velocity (ξ, η, ζ) in a magnetic field (α, β, γ) .

By FARADAY'S principles the motion leads to electric force $(\eta\gamma - \xi\beta, \zeta\alpha - \xi\gamma, \xi\beta - \eta\alpha)$ in addition to that arising from electrostatic distribution; as the distribution of current is here steady, it does not contribute.

On the principle of the theory of electrons, this part of the force, depending on the velocity of motion, acts on the electrons of the moving dielectric only, thus contributing to its polarisation (f', g', h') , but does not contribute to the ethereal electric displacement (f, g, h) . Thus, with electrostatic units,

$$f' = \frac{K - 1}{4\pi} (P' + \eta\gamma - \zeta\beta), \text{ where } f = \frac{1}{4\pi} P',$$

with two other similar equations. We may take these equations to represent the radial components, here the only ones. Now the total electric displacement of MAXWELL, represented here by $f + f'$, is circuital, so that $(f + f') \cdot 2\pi r$, its amount per unit

length measured axially across a concentric cylinder of radius r , is the same for all values of r ; it is equal to $-Q$, the charge per unit length with changed sign on the inner face of the outside coating of the cylindrical condenser. Moreover, P' is here $-dV/dr$, where V is the potential of the electrostatic distribution because it is a steady one. Thus, n being the number of revolutions per second in the axial magnetic field H ,

$$-Q = \frac{K}{4\pi} \left[-2\pi r \frac{dV}{dr} + \left(1 - \frac{1}{K}\right) 2\pi r \cdot nH2\pi r \right].$$

Integrating this equation from $r = r_1$ to $r = r_2$ we get

$$-\frac{2Q}{K} \log \frac{r_2}{r_1} = -(V_2 - V_1) + \left(1 - \frac{1}{K}\right) \pi nH (r_2^2 - r_1^2).$$

Let C be the capacity, between the two coatings, of unit length of the cylinder, also let $V_2 - V_1 = V$, and $E = (1 - K^{-1}) \pi nH (r_2^2 - r_1^2)$; then this equation becomes $-Q/C = -V + E$.

Now, if the capacity of the connected apparatus, consisting of the outside surface of the outside coating together with the connecting wires and electrometer, is C' , and if we now let Q and C each apply to the whole length of the actual cylinder, we have $-Q/C = -V + E$; and $V = -Q/C'$, as the total charge of the system is zero; so that, eliminating Q , we get $E = V(C + C')/C$.

This equation will be true for the actual cylinder of finite length if C is taken to be the actual capacity between the outside and inside coatings, which of course will be a little greater than $\frac{Kl}{2 \log r_2/r_1}$, where l is the length of the cylinder.

Suppose now that a quantity of electricity, q , given to the whole insulated system produces a rise of potential v , so that $v = q/(C + C')$, then multiplying the equation $E = V(C + C')/C$ by this, we get $E = V/v \cdot q/C$. If the electrometer deflection due to V is D , and that due to v is d , this equation may be written $E = D/d \cdot q/C$.

Thus E can be determined in terms of the two deflections of the electrometer, the known charge, and the capacity between the outside and inside coatings of the cylinder. It has been assumed in the above discussion of the theory of the experiment that the magnetic force is everywhere parallel to the axis of the rotating cylinder. In the actual experiments this was only approximately the case. The necessary corrections on this account are considered in Section 4.

(2.) *Description of Apparatus.*

A Government Grant from the Royal Society of £36 was obtained in 1903 to cover the cost of apparatus for the experiment. The apparatus used was originally made by W. G. PYE & Co., of Cambridge, but it was afterwards modified in detail by the mechanics of the Cavendish Laboratory workshop.

The apparatus was first set up in October, 1903, and the existence of the effect was almost immediately discovered. Various disturbing causes prevented accurate measurements being made, but these were ultimately nearly got rid of by suitable modifications of the apparatus. The apparatus described below is the final form

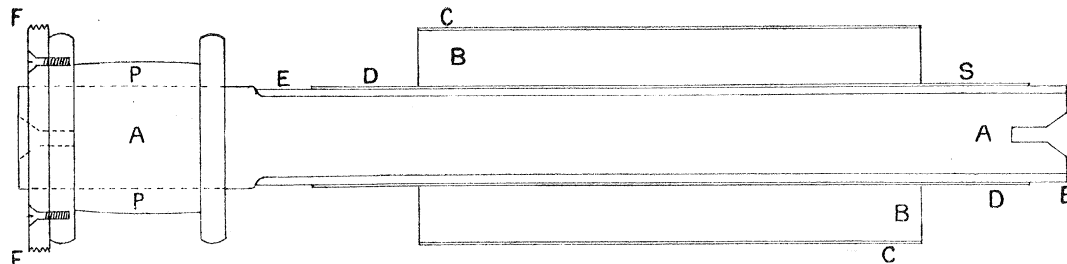

Fig. 1. AA, phosphor bronze axle; BB, ebonite cylinder; CC, brass tube; DD, brass tube; EE, vulcanised fibre tube; FF, revolution counter disk; PP, driving pulley.

adopted, with which it was found possible to make measurements of the induced electromotive force.

The dielectric cylinder used in the experiments was of ebonite, 9.97 centims. long, 4.15 centims. outside diameter, and 2.01 centims. inside diameter. It was mounted on a phosphor bronze axle, as shown in fig. 1, which is drawn to scale.

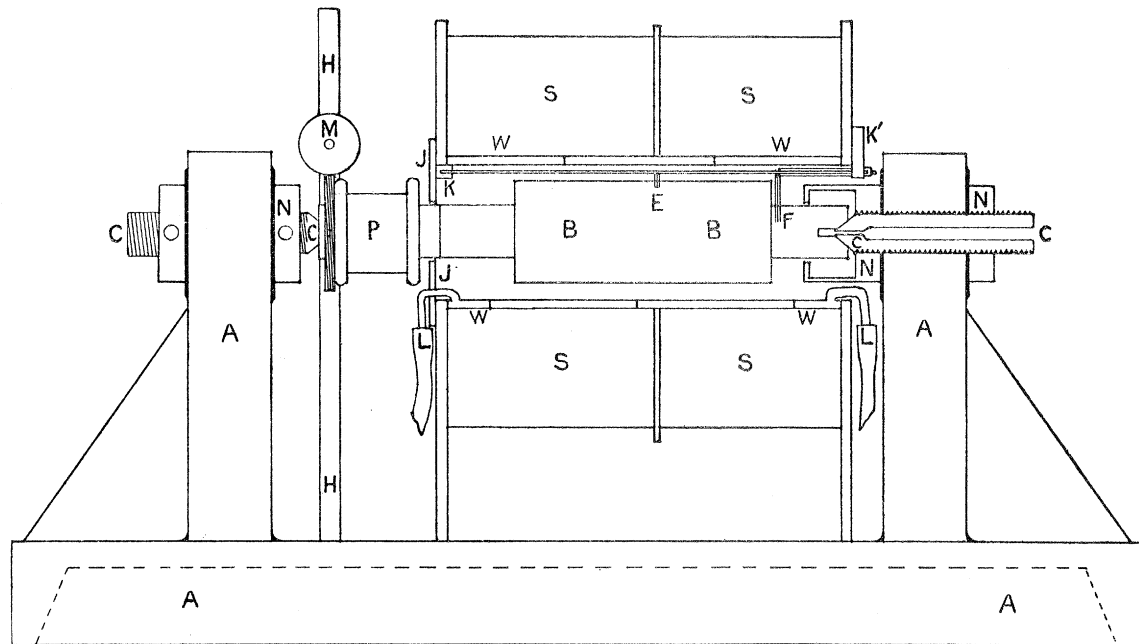

Fig. 2. AAAA, steel casting; BB, ebonite cylinder; CCCC, steel screws with cones; E, F, brushes; HH, rod supporting revolution counter; JJ, plates closing end of solenoid; KK', ebonite blocks supporting brushes; LL, tubes for water jacket; M, revolution counter wheel; NNNN, lock nuts; P, driving pulley; SSSS, magnetising solenoid; WWWW, water jacket.

The tube DD was insulated from the axle by the tube EE of vulcanised fibre. The tube DD was connected to earth during the experiments by a sliding contact

at S, so that the charging up of the surface of the axle due to its rotation in the magnetic field could not affect the potential of the outside coating CC of the ebonite cylinder.

The magnetic field was produced by a solenoid 16 centims. long, 5·3 centims. inside, and 15 centims. outside diameter, having 95·5 turns per centim. The axle was supported by hard-steel cones, on which it turned, which were carried by a heavy cast-steel mounting. Fig. 2 shows the mounting of the cylinder and solenoid drawn to scale, and fig. 3 is a vertical section perpendicular to the axis of the cylinder.

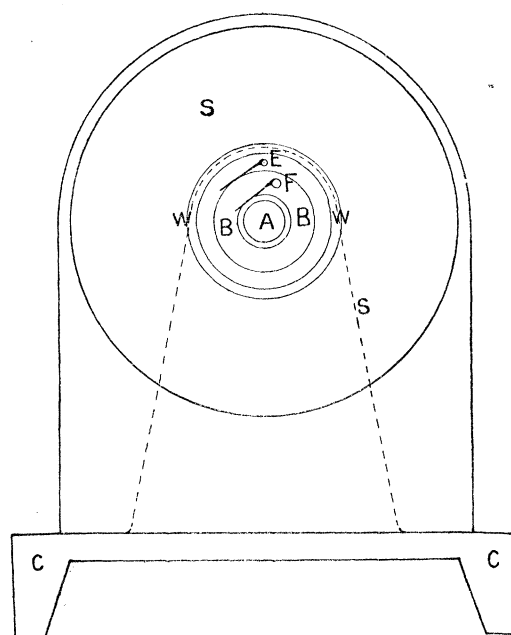

Fig. 3. A, phosphor bronze axle ; BB, ebonite cylinder ; EF, brushes ; WW, water jacket ; SS, solenoid ; CC, steel base. Dotted line = pillar supporting bearing.

The steel cones were bored through as shown, and connected to an oil reservoir (see fig. 4) about 2 feet above the level of the bearings. Oil was thus supplied under pressure at the axis of the bearings, and the lubrication was so good that even when running continuously at 200 revolutions per second the bearings did not get hot.

The sliding contact or brush at E, fig. 2, was supported by a brass rod carried at each end by ebonite plates screwed to the frame of the solenoid. The rod could rotate freely in holes in the ebonite, and at K' a small lever was attached to it, the weight of which kept the brush pressed against the rotating cylinder. The brush was formed of about 15 thin brass wires soldered side by side at right angles to the brass rod.

A similar brush arrangement at F, fig. 2, was carried by a brass tube passing through the ebonite plate K', and was kept pressed against the rotating tube by a small lever at K', pulled down by a spiral spring.

The end JJ of the solenoid was closed by two semi-circular brass plates screwed on as shown. These served to screen off electrostatic effects due to the driving belt charging up. The inside surface of the solenoid was kept cool by means of the water jacket WWWW, through which a rapid stream of tap water was always kept flowing when the apparatus was in use. The water was made to flow in a spiral path round the solenoid by means of a spiral partition inside the jacket.

The solenoid was wound on a brass bobbin in two sections, and the windings were carefully insulated from the bobbin. A current of 15 ampères could be passed for some time through the solenoid, using a P.D. of about 50 volts, without undue heating.

The cylinder was driven by a leather belt 2 centims. wide and 0.3 centim. thick, with a very well made splice. The belt was driven by a half horse-power continuous, current motor which ran at about 1450 revolutions per minute with 50 volts. Three driving pulleys were used, 10 inches, 5 inches, and $2\frac{1}{2}$ inches respectively in diameter. The pulley on the cylinder shaft was $1\frac{1}{4}$ inches in diameter, so that speeds of about 11,600, 5800 and 2900 revolutions per minute could be obtained.

The arrangement of the apparatus is shown in fig. 4. The number of revolutions

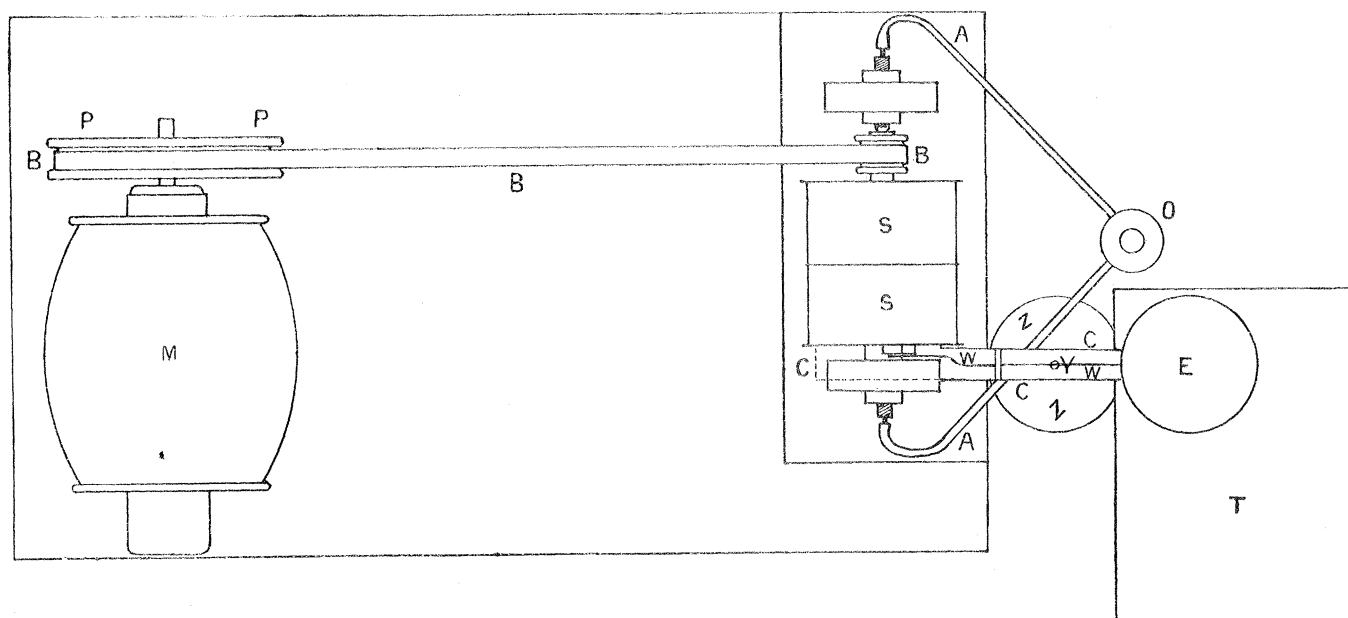

Fig. 4. AA, tubes taking oil to bearings; BBB, driving belt; CCC, metal screen round insulated wire; E, quadrant electrometer; M, $\frac{1}{2}$ -H.P. motor; O, oil reservoir; PP, motor pulley; SS, solenoid; T, electrometer table; WW, insulated wire; Y, mercury cup; Z, guard-ring condenser.

made by the cylinder could be registered on a small speed counter. A brass disk FF (fig. 1), having a screw thread cut on its circumference, was screwed on to the driving pulley. The screw thread geared into a cog-wheel with 100 teeth carried on the axle of a 'Veeder' revolution counter, indicating from 0 to 99,999 revolutions.

The speed counter was supported on a steel rod, so that it could be slipped up and down into position, and oil was supplied to the screw thread through a pipe leading to the oil reservoir. The number registered by the revolution counter in about 2 minutes was usually taken when determining the speed. It was found that the speed observed agreed very nearly with that deduced from the speed of the motor and size of the pulleys, and also that the speed remained very constant for long intervals of time. In fact, no appreciable variation of the speed ever occurred during any of the experiments, the results of which are recorded in this paper.

The motor and solenoid were run from two different sets of cells, so that varying the current in the solenoid did not affect the voltage on the motor. This latter voltage was always indicated by a Weston voltmeter, so that if any change in it occurred, it was at once known that something was wrong. The current through the solenoid was measured by a very good Weston ammeter, which read from 0 to 20 ampères, and it could be reversed by means of a mercury-cup commutator.

The motor and the apparatus described were screwed down to a large wooden board, which was supported on a stone slab in the Cavendish Laboratory. Heavy weights were placed on the board, and the apparatus was very steady, even when running at 200 revolutions per second.

It remains now to describe the quadrant electrometer and its connections, and the arrangement used for determining its sensibility. The quadrant electrometer used was of the Dolezalek type.* It was placed on a separate table standing on the floor, and was not affected at all by the vibrations set up by the rotating cylinder. The quadrants were supported by "amberoid" pillars, which were found to insulate very well. The needle was suspended by a quartz fibre, and was charged by touching it with a wire connected to one pole of a battery of secondary cells, the other pole of which was connected to the case and quadrants of the electrometer. A concave mirror 7 millims. in diameter was attached to the needle, and the deflection of the needle was observed by means of the image of an incandescent lamp filament, formed by this mirror on a millim. scale, distant 2 metres from the electrometer. The image was $\frac{1}{5}$ millim. wide and perfectly sharply defined. Its position could be easily read to $\frac{1}{5}$ millim. The loss of charge by the needle through the surrounding air and the quartz fibre diminished the sensibility of the electrometer for potential difference about 50 per cent. in 24 hours. The needle was usually charged up to a potential of 40 volts, at which potential the sensibility for quantity of electricity was a maximum.

During the course of a series of measurements the sensibility of the electrometer, for quantity of electricity, was measured from time to time, but the variations were inappreciable, owing to the very slow rate at which the sensibility of the electrometer, for quantity, varied with the potential of the needle when the sensibility for quantity was near its maximum value. The torsion of the quartz fibre used was just

* DOLEZALEK, 'Zeits. für Instrument.,' December, 1901.

small enough to make the electrometer needle "dead-beat" when at the maximum sensibility for quantity. The damping of the needle was done by the air inside the quadrants.

One pair of the quadrants was always connected to the case and to earth, while the other pair was connected, by a wire about 2 feet long, to the brush which made contact with the outside coating of the ebonite cylinder. This wire was completely enclosed in metal tubes, which, together with the electrometer case, the metal bobbin of the solenoid and the inner coating of the ebonite cylinder, formed a complete metallic screen, all connected together and to earth, surrounding the insulated parts of the apparatus. Outside electric disturbances had no effect whatever on the electrometer needle. For example, reversing the current through the solenoid was repeatedly proved to produce no deflection of the electrometer needle when the cylinder was not rotating. Also running the motor had no effect on the electrometer.

The wire WW (fig. 4) leading from the brush to the electrometer was supported by a sealing-wax rod and by an arrangement which was used to determine the electrometer sensibility for quantity. This consisted of a small circular parallel plate guard-ring condenser, ZZ. The plates of this condenser were held 2.00 centims. apart by three ebonite pillars, and the lower plate and guard ring were each 13.0 centims. in diameter. The hole in the guard ring was 3.05 centims. in diameter and the condenser plate 2.95 centims. in diameter. The plates were all made of brass 0.5 centim. thick, and were turned up truly plane. The condenser plate was supported by a disk of ebonite screwed down on the guard ring, and it carried a rod, on the top of which was a mercury cup, Y (fig. 4). The wire WW was supported by this rod. A brass rod could be let down into the mercury cup when it was desired to connect the insulated parts of the apparatus to the metallic screen surrounding them. This rod was soldered to a wire spring, the other end of which was soldered to the tube containing the wire WW.

The larger plate of the condenser was connected with a commutator, by means of which it could be either connected to earth or charged up by means of a battery of small secondary cells.

To determine the sensibility of the electrometer for quantity the insulated parts were first earthed and the larger plate of the condenser charged to a potential of V volts. A quantity of electricity, q ($q = CV/300$ electrostatic units, where C is the capacity of the guard-ring condenser), was thus induced on the small condenser plate. The rod at Y was then raised and the electrometer scale reading noted. The larger plate of the condenser was then earthed, so setting free the quantity of electricity q on the insulated parts of the apparatus. The resulting deflection was then read off and was taken to be the deflection due to the quantity of electricity q . It was verified carefully that the deflection was proportional to q .

The sensibility of the electrometer for potential difference was measured when

required by means of a potentiometer consisting of 100 resistance coils, each of 100 ohms resistance. A known P.D. was applied to the 100 coils in series and the deflection due to the P.D. on one or two of the coils measured.

(3.) *Method of Experimenting and Results.*

The method of performing an experiment was very simple. The motor was started and the water set running through the water-jacket and the rate of revolution measured. The electrometer quadrants and outside coating of the rotating cylinder were then insulated by pulling up the rod out of the mercury cup. The scale reading of the electrometer was then observed, and, if it remained steady, a current was passed through the solenoid and the resulting deflection noted. The current was then reversed several times and the corresponding deflections measured. The rate of revolution was measured again and then the motor stopped and the sensibility of the electrometer for quantity tested.

The difficulty in making these observations was that the index of the electrometer often did not remain steady, but wandered about in a more or less irregular manner. The adoption of the water-jacket effected a great improvement in this respect, but the chief point to be attended to in order to get the index steady was found to be the adjustment of the sliding contacts. In the first place it was found necessary to have the surfaces on which the brushes pressed turned true very carefully, and the bearings adjusted, so that there was no shaking when running. The trueness of these surfaces was tested as follows: the end of the lever attached to the rod carrying one of the brushes was observed with a low-power microscope and the cylinder slowly rotated. If the surface was not true or the bearings loose, the lever moved up and down. The bearings were adjusted and the cylinder repeatedly re-turned until the levers remained steady on rotating slowly.

Another thing which required careful adjustment was the pressure of the brushes on the moving surfaces. If the pressure was too great the surfaces got hot and a pyroelectric effect was produced which caused a continual drift of the electrometer index. In the earlier experiments the outside surface of the ebonite was coated with graphite to form a conducting coating. But after running a few minutes the graphite got rubbed off and the ebonite under the brush caught fire. A metallic coating therefore had to be used to conduct away the heat generated by the friction.

If the brushes were not sufficiently tightly pressed down the index also drifted continually, but in the opposite direction to the drift which appeared to be due to heating. The drift, when the brushes were not sufficiently tightly pressed down, was especially rapid when the surfaces were not true or the bearings loose. The cause of this drift is not certain, but it seems probable that it was due to the brush jumping on and off the surface and to particles of matter being torn off at each impact and carrying a charge away with them. This theory was confirmed by

putting oil on the brushes, which was thrown off by the centrifugal force and caused a very rapid drift in the same direction as that obtained when the brushes were not pressed down enough. By carefully adjusting the bearings and brushes the index was got to remain very fairly steady on a number of occasions and the measurements recorded below were obtained. The pressure of the brushes was adjusted by hanging small weights on the levers.

If the index was drifting slowly at a uniform rate, then measurements could still be made by taking the deflection first in one direction and then in the other, and taking the mean of the two as being the true deflection. Measurements got in this way agreed with those obtained when the index was steady, but the measurements given in the table below were obtained with the index very nearly steady, so that the deflections were nearly the same in either direction.

For example, on one occasion a current of 7.5 ampères on reversing gave a deflection of 13.8 millims. one way and 13.0 millims. the other way. The index then began to drift and the deflections became 25.0 millims. one way and 2.5 millims. the other way. The mean of the first pair is 13.4 millims. and that of the second pair 13.7 millims.

On several occasions the index remained almost steady for some minutes and it was verified very carefully that the deflection on reversing the current was a permanent one and not merely a throw. The variation of the scale reading with the time on one occasion is shown in fig. 5. The magnetic field was put on at A, reversed at B and C,

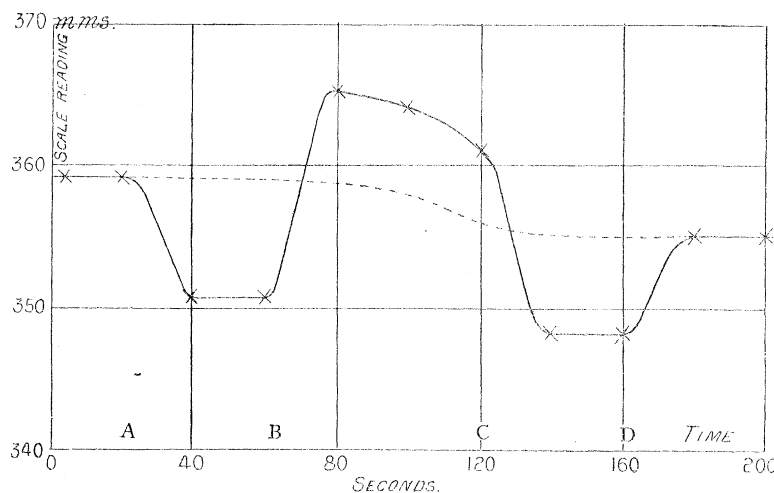

Fig. 5.

and taken off at D. It will be seen that between B and C a change in the zero occurred which is indicated approximately by the dotted line. This diagram (fig. 5) indicates the sort of results that could usually be obtained when the apparatus was working fairly well. But, as already mentioned, on several occasions the index remained quite steady for some minutes, and many of the results recorded below were obtained on one or another of these occasions.

The following table gives the results obtained with various magnetic fields and rates of revolution.

No.	Revolutions per second. (n).	Current reversed. (C).	Electrometer sensibility. (S).	Deflection. (δ).	Number of deflections of which mean was taken.	$\frac{10^5 \delta}{nCS}$	Difference from mean.
1	192	ampères. 14·8	214	millims. 26·2	4	4·30	per cent. - 0·2
2	192	7·5	214	13·6	2	4·41	+ 2·3
3	192	3·8	214	6·8	2	4·35	+ 0·9
4	192	3·2	214	5·3	2	4·03	- 6·5
5	183	14·2	170	18·0	2	4·08	- 5·3
6	183	7·1	170	9·2	3	4·16	- 3·5
7	182	11·6	215	19·9	7	4·38	+ 1·6
8	100	14·0	225	14·0	2	4·44	+ 3·0
9	100	11·0	225	10·5	2	4·24	- 1·6
10	100	6·7	225	7·0	2	4·64	+ 7·7
11	100	5·4	225	5·0	2	4·11	- 4·6
12	93	11·0	217	9·5	2	4·28	- 0·7
13	92	14·6	170	10·0	2	4·38	+ 1·6
14	92	12·6	170	8·0	2	4·06	- 5·8
15	92	6·5	170	4·5	2	4·44	+ 3·0
16	49·2	12·0	225	6·0	4	4·51	+ 4·6
17	49·2	6·0	225	3·0	4	4·51	+ 4·6
Mean						4·31	3·4

The quantity δ/nCS in the above table is approximately constant, which shows that the deflection on reversing the current in the solenoid was proportional to the current reversed, to the rate of revolution of the cylinder, and to the sensibility of the electrometer for quantity.

The numbers in the column headed "Electrometer sensibility" are the deflection due to the charge induced on the small plate of the guard-ring condenser when a difference of potential of 38·0 volts was maintained between the two plates of the condenser. Denoting this charge by q , and the capacity of the condenser by a , we have $q = a38/300$ electrostatic units. Now $a = A/4\pi d$, where A is the effective area of the small plate and d the distance between the plates. Hence

$$a = \frac{\pi (1.50)^2}{4\pi \times 2.00} = 0.2813 \text{ centim.},$$

so that $q = \frac{0.2813 \times 38}{300} = 0.0356$ electrostatic unit.

The quantity of electricity (Q) required to produce a deflection equal to that obtained by reversing C ampères with n revolutions per second is therefore

$$Q = q\delta/S = 15.35 \times 10^{-7} Cn \text{ electrostatic unit.}$$

(4.) *Comparison of the Results Obtained with the Theory.*

In section (1) we obtained an expression for the electromotive force (E) in the ebonite, which was $E = V(C + C')/C$. Now $V(C + C')$ is the quantity of electricity required to produce a deflection equal to that due to E , so that, supposing that Q is all produced by E , we get, theoretically, $Q = EC$.

Now $E = (1 - K^{-1}) \pi n H (r_2^2 - r_1^2)$, so that E should be proportional to n and H ; and H is proportional to C , so that, theoretically, Q should vary as Cn in agreement with the results obtained.

The direction of E should be theoretically the same as the induced electromotive force in a conductor moving in a magnetic field. It was verified repeatedly when doing the experiments that the sign of the charge indicated by the observed deflections was the same as would have been obtained if the rotating cylinder had been a conductor. The results obtained are therefore in complete agreement with the theory, as regards the direction of the effect and its variation with the magnetic field and rate of revolution.

To complete the comparison of the results with the theory, it is necessary to calculate the magnitude of the effect which ought to be obtained according to the theory with the apparatus used. The simple formula $E = \pi n (1 - K^{-1}) H (r_2^2 - r_1^2)$ cannot be used for this purpose, because in the actual apparatus H was not uniform, owing to the finite length of the solenoid. Further, the induced electromotive forces in the conducting coatings of the cylinder have to be calculated, and the small effects due to them added to the effect due to the electromotive force in the ebonite to obtain the full theoretical value of the observed effect. The quantities to be determined are therefore: (1) the capacity C of the ebonite cylinder; (2) the specific inductive capacity of the ebonite; and (3) the distribution of the magnetic field due to the solenoid in the region occupied by the cylinder. The determination of (1) and (2) will first be described.

To determine the capacity between the inside and outside coatings of the cylinder, the inside coating was connected through a commutator to a potentiometer, so that it could be charged up when required to a known potential. The outside coating was first connected to earth and then the inside coating charged up. The outside coating was then insulated and the inside coating put to earth. The resulting deflection of the electrometer gave the charge induced on the outside coating in terms of the electrometer sensibility, as determined by means of the small guard-ring condenser. The deflection due to charging the inside coating to 0.400 volt on one occasion was 185 millims. The electrometer sensibility was then 0.000184 electrostatic unit per millimetre, so that the capacity required is $300 \times 185 \times 0.000184 \div 0.400 = 25.5$ centims. The mean of several determinations done during the course of the experiments was 25.4 centims.

To determine the specific inductive capacity of the ebonite, the outside coating was

cut into three parts and the capacity of the middle part found in the way just described, using the end parts as guard rings. The electrometer sensibility was 0·000150 electrostatic unit per millimetre, and charging the inside coating to 0·400 volt gave a deflection of 107 millims. The capacity of the middle part was therefore 12·0 centims. The length between the centres of the two cuts (each $\frac{1}{2}$ millim. wide) in the outside coating was 4·95 centims. The capacity of the cylinder per unit length was therefore $\frac{1}{4} \cdot \frac{2 \cdot 0}{95} = 2 \cdot 425$ centims. Now the capacity per unit length is $\frac{K}{2 \log r_2/r_1}$; hence $K = 2 \log r_2/r_1 \times 2 \cdot 425$, or $K = 4 \cdot 85 \log \frac{4 \cdot 15}{2 \cdot 01} = 3 \cdot 54$.

The value obtained for K depends on the time allowed to elapse between discharging the inside coating and reading the electrometer deflection. This is due to the leaking out of residual charge from the ebonite. In the experiments on the effect due to rotating the cylinder in a magnetic field the deflection of the electrometer was read as soon as the index came to rest after reversing the field. In measuring the specific inductive capacity, therefore, the same plan was adopted, so that the specific inductive capacity obtained corresponds to a time of discharge equal to the time taken by the electrometer index to move from the zero position to its new position. The electrometer needle was just dead-beat, so that this time was fairly constant and was about 15 seconds.

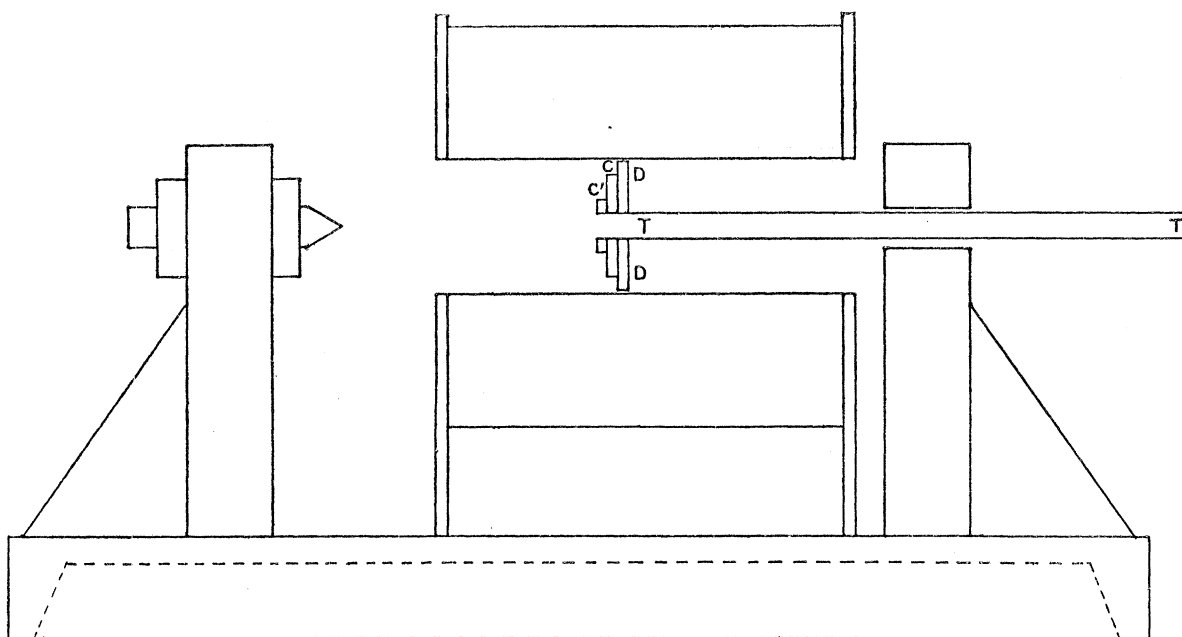

Fig. 6. TT, brass tube; DD, ebonite disk; CC', coils.

The variation of the magnetic field along the solenoid was measured by means of two coils of fine wire wound on an ebonite disk which could be slid along the axis of the solenoid. The arrangement is shown in fig. 6.

DD is the ebonite disk with coils wound on it at C and C'. The disk was attached

as shown to a brass tube TT, through which the wires leading to the coils were brought out. The coil C consisted of a single layer of fine silk-covered wire having 9 turns, and its mean diameter was 4.28 centims. The ends of the wire were twisted together and connected to an Ayrton-Mather ballistic galvanometer. The coil C' was similar to C, and its mean diameter was 2.01 centims. The deflection of the galvanometer coil, due to reversing a known current in the solenoid, was determined for each of the coils C and C' at a series of positions along the axis of the solenoid. The coils C and C' were then put at the centre of a solenoid, 50 centims. long and 5.4 centims. in diameter, consisting of a single layer of wire, with 4.375 turns per centimetre, wound on a brass tube. Known currents were then reversed in this long solenoid and the galvanometer deflections with the coils C and C' measured. The current was passed along the brass tube to neutralize the field due to the component of the current along the solenoid. The field strength at the centre of this solenoid was calculated, and so the sensibility of the galvanometer with each of the coils C and C' was obtained. The magnetic field due to the solenoid used to produce the field in which the cylinder was rotated was found to be proportional to the current through it throughout the region occupied by the cylinder. The following table gives the results obtained for the change in the mean field strength due to reversing one ampère for each of the coils C and C' :—

Distance of coil, from end of cylinder near the pulley, in centimetres.	Coil C. (Radius 2.14 centims.)	Coil C'. (Radius 1.00 centim.)
0	168	168
1	186	183
2	195	193
3	200	199
4	203	202
5	206	205
6	207	207
7	207	208
8	207	208
9	205	205
10	201	199
10.3	—	196

The mean field through the coil C, due to a current of 2 ampères, over the length of the cylinder calculated from these numbers is 200.0, and that through the coil C' is 199.4. The mean induction through the ebonite is consequently

$$200 \pi r_2^2 - 199.4 \pi r_1^2 = 2067.$$

The mean induction through the outside coating is $\pi (r_3^2 - r_2^2) 200 = 132$, where r_3 is the radius of the outside coating. Here $2r_3 = 4.25$, $2r_2 = 4.15$ and $2r_1 = 2.01$ centims.

The quantity which has been determined experimentally is the charge which, when given to the outside coating, will produce a deflection equal to that observed on reversing the magnetic field. Now, if both the brushes were connected to earth, the charge induced on the outside coating would be equal and opposite to this charge which has been determined. This follows at once from the equation $EC = V(C + C') = Q$, because when both surfaces of the cylinder are at zero potential the induced charge is evidently $-EC$, E being understood just now to include the induced electromotive forces in the coatings as well as the induced electromotive force in the ebonite.

The brush on the outside surface was at the centre of the cylinder, where the field strength is 206. Consequently the outside surface of the cylinder had a mean potential, $Cn(206 - 200) \pi r_3^2 = +85 Cn$ electromagnetic units below that of the brush. The mean potential of the inside surface of the outside coating was therefore $+(132 + 85) Cn = +217 Cn$ electromagnetic units below the brush. The field at the brush on the inside coating was 196, so that the mean potential of the inside coating was $Cn(199.4 - 196) \pi r_1^2 = 11 Cn$ electromagnetic units above that of the brush. The capacity between the inside and outside surfaces was 25.4 centims., and that between the outside surface and the surrounding tube 24 centims. Consequently the charges induced on the outside coating, when both brushes were earthed, were

$$Q''' = Cn(217 + 11) 25.4/3 \times 10^{10} \text{ electrostatic units}$$

on the inside surface, due to the electromotive forces in the coatings.

$$Q'' = Cn(+85) 24/3 \times 10^{10} \text{ electrostatic units}$$

on the outside surface, due to the electromotive force in the outside coating, and

$$Q' = (1 - K^{-1}) Cn(2067 \times 25.4)/3 \times 10^{10} \text{ electrostatic units}$$

on the inside surface, due to the electromotive force in the ebonite. These equations give, since $K = 3.54$,

$$Q' = 12.58 \times 10^{-7} Cn, \quad Q'' = 0.68 \times 10^{-7} Cn, \quad Q''' = 1.93 \times 10^{-7} Cn \text{ electrostatic unit.}$$

Thus the total charge on the outside coating was $15.19 \times 10^{-7} Cn$, and this should be equal to Q , which was found experimentally to be $15.35 \times 10^{-7} Cn$ electrostatic unit. It thus appears that the charge, as calculated by the theory, agrees with that found within the limits of experimental error. The difference between the effect calculated and the mean effect found is only 1 per cent. Subtracting Q'' and Q''' from the effect found we get $12.74 \times 10^{-7} Cn$ electrostatic unit, which may be regarded as the experimental value of the effect due to the ebonite alone. The corrections Q'' and Q''' though somewhat large are not open to any doubt, because

the induced electromotive force in a conductor when moving in a magnetic field is accurately known.

The equation $Q' = \frac{2067 \times 25.4}{3 \times 10^{10}} \times (1 - K^{-1}) Cn$ can be used to calculate K from the experimentally-found value for Q' . It gives $K = 3.68$, which is 4 per cent. greater than the value found by measuring the capacity of the cylinder.

The following table contains a comparison of the observed deflections with those calculated by means of the theoretical formula $15.19 \times 10^{-7} Cn = Q = \delta q/S$, where δ is the deflection due to the effect, and S the electrometer deflection due to a charge q .

n .	C .	S .	δ . (Observed.)	δ . (Calculated.)
192	14.8	214	26.2	26.0
192	7.5	214	13.6	13.2
192	3.8	214	6.8	6.7
192	3.2	214	5.3	5.6
183	14.2	170	18.0	18.8
183	7.1	170	9.2	9.4
182	11.6	215	19.9	19.4
100	14.0	225	14.0	13.4
100	11.0	225	10.5	10.5
100	6.7	225	7.0	6.4
100	5.4	225	5.0	5.2
93	11.0	217	9.5	9.5
92	14.6	170	10.0	9.7
92	12.6	170	8.0	8.4
92	6.5	170	4.5	4.3
49.2	12.0	225	6.0	5.7
49.2	6.0	225	3.0	2.9

(5.) *Summary of Results and Conclusion.*

From the results of the experiments described above it may be concluded that:—

- (1) A radial electric displacement is produced in a dielectric such as ebonite when it is set rotating in a magnetic field parallel to the axis of revolution ;
- (2) The direction of this displacement is the same as that which would be produced in a conductor similarly situated ;
- (3) The displacement is proportional to the magnetic field and to the rate of revolution ;
- (4) The amount of the displacement agrees with that calculated on the assumption that an electromotive force is induced in the dielectric equal to that in a conductor multiplied by $1 - K^{-1}$, where K is the specific inductive capacity of the dielectric.

The results obtained are consequently in complete agreement with MAXWELL'S electromagnetic theory, as developed by H. A. LORENTZ and LARMOR.

According to HERTZ'S form of MAXWELL'S theory the induced electromotive force in a dielectric is equal to that in a conductor. The experiment described may consequently be regarded as a crucial experiment deciding in favour of LORENTZ and LARMOR'S theory and against HERTZ'S theory.

In conclusion, I wish to say that I am indebted to Professor LARMOR for valuable advice and help with regard to the theory of the experiment. My best thanks are also due to Professor J. J. THOMSON for his never failing encouragement and valuable suggestions given throughout the course of the work, which was done in the Cavendish Laboratory.

